

(A) FLOWING WELL TO A BATTERY

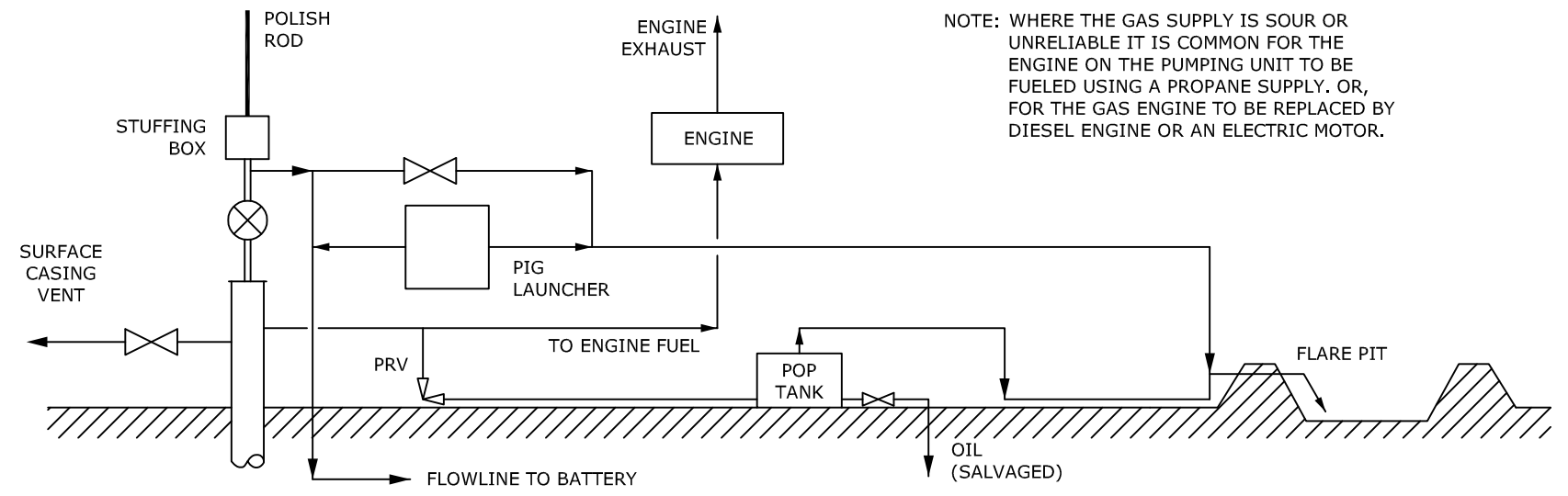

(B) PUMPING WELL TO A BATTERY

NOTE: WHERE THE GAS SUPPLY IS SOUR OR UNRELIABLE IT IS COMMON FOR THE ENGINE ON THE PUMPING UNIT TO BE FUELED USING A PROPANE SUPPLY. OR, FOR THE GAS ENGINE TO BE REPLACED BY DIESEL ENGINE OR AN ELECTRIC MOTOR.

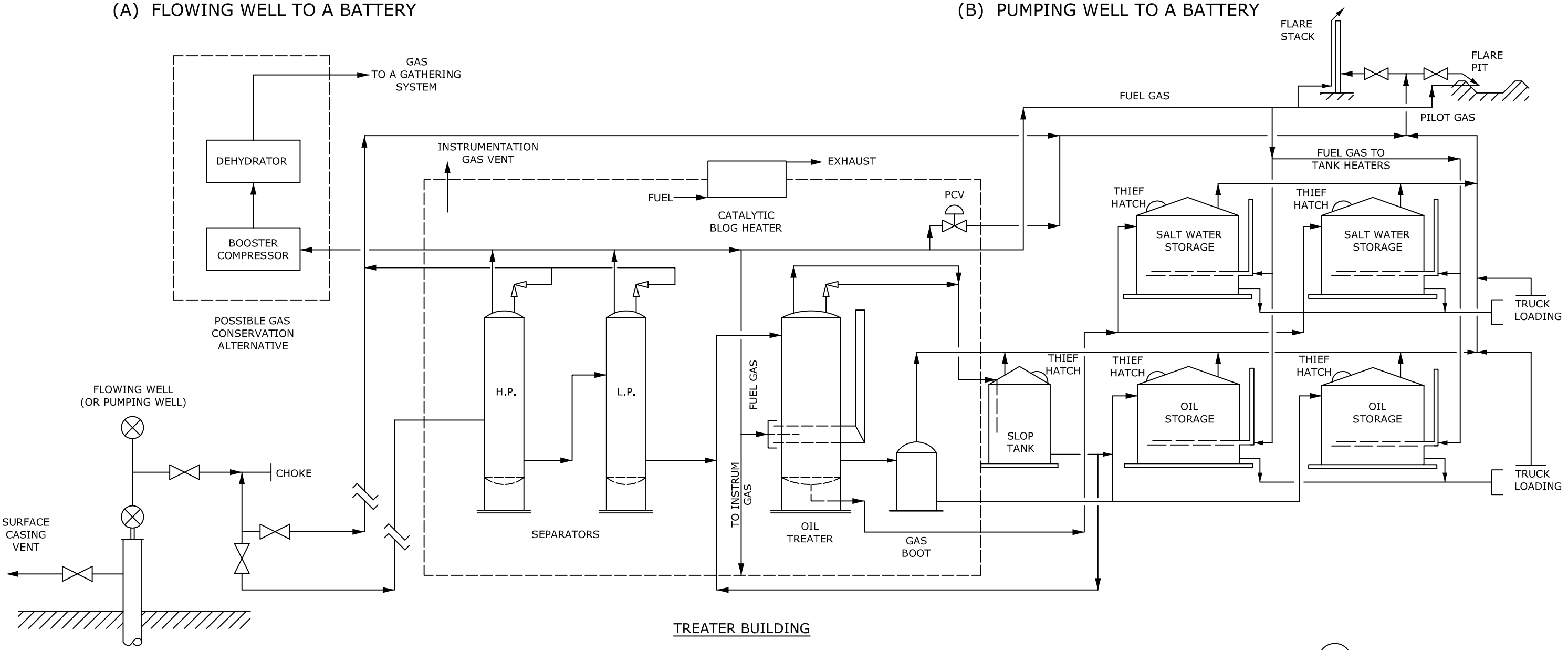

(C) SINGLE-WELL BATTERY
(PRODUCTION FACILITIES ON THE WELL SITE)

PCV PRESSURE CONTROL VALVE
PRV PRESSURE RELIEF VALVE